

1 piece Wafer type full port ball valve flange end

ITEM	PARTS	Q'TY	MATERIAL
1	BODY	1	ASTM-A351 -CF8M
2	INSERT	1	ASTM-A351 -CF8M
3	BALL	1	ASTM-A351 -CF8M
4	BALL SEAT	2	PT FE
5	JOINT GASKET	1	PT FE
6	STEM	1	AISI316
7	THRUST WASHER	1	PTFE
8	STEM PACKING	2	PTFE
9	HIGH WASHER	1	AISI 304
10	HANDLE	1	AISI 304
11	SPRING WASHER	1	AISI 304
12	STEM NUT	2	AISI 304
13	PLASTIC COVER	1	PLAST IC
14	STOP PIN	1	AISI 304

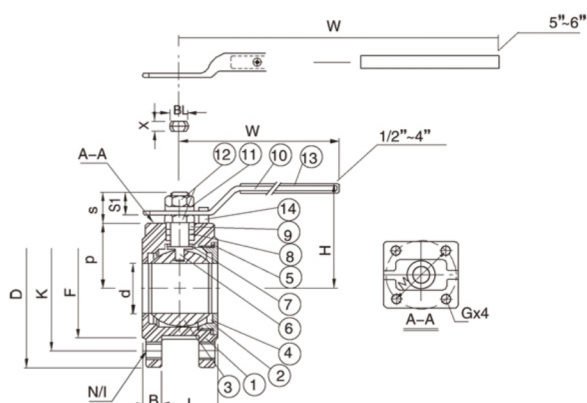
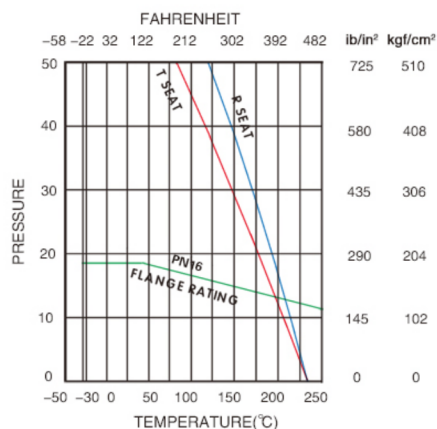

1 delige geflensde kogelkraan FB wever type

		d	L	D	K	N/1	B	F	P
1-delige geflensde kogelkraan DN15	PN16	15	40	95	65	4-M 12 x 1,75	14	45	34,5
1-delige geflensde kogelkraan DN20	PN16	20	44	105	75	4-M 12 x 1,75	16	58	38,5
1-delige geflensde kogelkraan DN25	PN16	25	53	115	85	4-M 12 x 1,75	16	68	44,6
1-delige geflensde kogelkraan DN32	PN16	32	58,4	140	100	4-M 16 x 2,00	16	78	51
1-delige geflensde kogelkraan DN40	PN16	38	62	150	110	4-M 16 x 2,00	16	88	55
1-delige geflensde kogelkraan DN50	PN16	50	72	165	125	4-M 16 x 2,00	18	102	63
1-delige geflensde kogelkraan DN65	PN16	65	94	185	145	4-M 16 x 2,00	18	122	73,5
1-delige geflensde kogelkraan DN80	PN16	76	118	200	160	8-M 16 x 2,00	20	138	94
1-delige geflensde kogelkraan DN100	PN16	96	140	220	180	8-M 16 x 2,00	20	158	105,5

S	S1	x	BL	IS05211G	H	W	CV Factor	Kgf/cm
17	10,5	6,5	10	F03	63	125	10	58
17	10,5	6,5	10	F03	68	125	25	80
24	16,5	8,7	14	F04	81	160	35	108
24	16,5	8,7	14	F04	87	160	46	150
29	21	10	16	F05	98	200	80	200
29	21	10	16	F05	105	200	110	300
36	26	12	20	F07	121	250	310	515
36	26	12	20	F07	153	285	350	810
36	26	12	20	F07	164	338	720	1130